



**INTERNATIONAL JOURNAL OF ENGINEERING SCIENCES & RESEARCH
TECHNOLOGY**

**PORTABLE SECURITY SYSTEM WITH PANIC SWITCH INCLUDING LOCAL AND
REMOTE ALARM**

Kapil Sekhar Borah

M.E Student, Electrical Department, Jorhat Engineering College, India

ABSTRACT

An earnest attempt has been made to devise a multifunctional system for Security. This portable system can be efficiently used for security against leakage of LPG, intruder detection and overheating. Some innovative power saving techniques has been implemented through the use of PIR sensor. Moreover, GSM acknowledgement of the parameters is achieved through the use of “SIM 900 GSM MODEM” and a “BUZZER” is used for local alarm. The readings and the status of the parameters are displayed on an LCD screen interfaced with the 8051(AT89S52) Micro-controller. A panic switch has been used for the emergency situation. When it is pressed, it will give both local and remote alarm. The panic switch along with the portable security system can be hidden by masking it with ordinary objects like portrait. If gas or intruder is detected or the room temperature exceeds a certain temperature limit or if the panic switch is pressed, local and remote alarm will be obtained.

A rechargeable battery is used which becomes effective when the main current source is cut off.

This project is designed to solve some day to day life problems of a common man providing 24 hours of security in a day.

KEYWORDS: AT89S52 Microcontroller, DS1620 Temperature sensor, MQ6 gas sensor, PIR sensor, JHD162A LCD, SIM900 GSM device

INTRODUCTION

Different features have been included in the project which can be life saving and energy saving at the same time. Every day, we get to read in the newspapers or on the internet about fire accidents caused due to the leakage in LPG cylinders at homes or offices or in a service station. Taking this in mind, LPG Leakage Detection System is incorporated in the project which uses MQ6 gas sensor to keep a track of the amount of LPG in the room where it is installed. If the level of LPG goes beyond a certain level, which can be hazardous, the system gives an alert signal to the concerned person and thereby avoiding the accident. Certain chemicals in the laboratories, medicines in the pharmacies or foods in a food industry have to be kept under some temperature limit. So the temperature has to be known every minute of the day. Electronic components are very sensitive to heat. And moreover, overheating may occur at home or offices due to incidents like short circuit of currents. So ‘Determination of Environmental Temperature’ is incorporated as a feature of the project. This feature uses a simple DS1620 temperature sensor which measures temperature from -55 to +125 degree Celsius. Whenever the temperature exceeds a certain limit, the security system will give alarm. When we are out of home/office, it becomes very important to detect, whether any person is entering home or office. For this purpose, a PIR sensor has been used which will detect unauthorised entry of persons. A BUZZER is used to produce local alarm. In some cases, human being fails to take decisions or to work properly due to incident e.g. when intruders get into home, whenever an elder person leaving alone becomes ill, people can’t effort to do much himself. For that kind of emergency situation, a panic switch is used, just pressing of which will give alarm indicating the emergency situation.

The most important feature of this project is the GSM acknowledgement of the parameters. GSM modem SIM 900 has been used in this project which provides an SMS alert of the status of different parameters which this project incorporates. All the above mentioned parameter measuring circuits are interfaced with a microcontroller AT89S52 of the 8051 family. This makes the device portable. Moreover, an LCD JHD162A is also interfaced with the microcontroller which is used for continuous displaying of the parameters and their status. A rechargeable battery is used in addition to the main current source. When there is no external current supply, this battery will provide power supply to the circuit. The power supply used for the device is also used for all the sensors. So the system is power saving one.

BLOCK DIAGRAM OF THE PROJECT

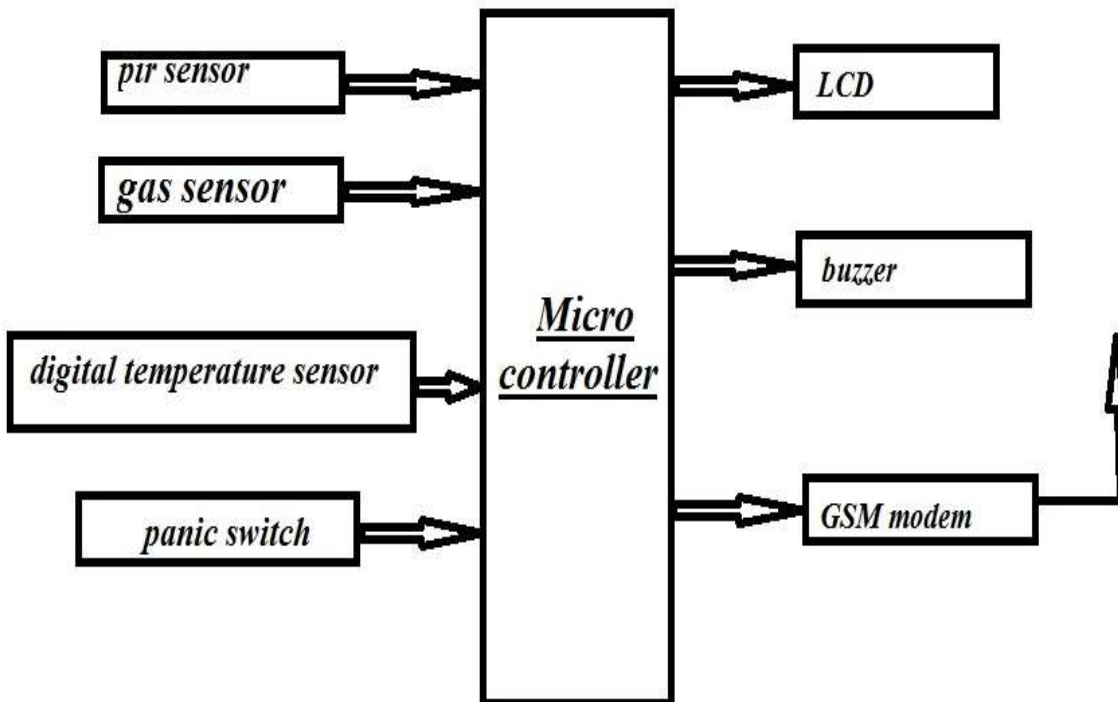

MATERIALS AND METHODS

LIST OF COMPONENTS USED

Sl. No.	Components	Specification
1	Microcontroller	AT89S52
2	Gas sensor	MQ-6
3	Temperature sensor	DS1620
4	PIR sensor	Energy/power saving
5	LCD panel	JHD162A

6	GSM modem	SIM 900
7	Voltage regulator IC	7805
8	Op-amp chip	LM358
9	Rechargeable battery	4hours battery backup
10	Panic switch	Emergency alarm

CIRCUIT DIAGRAM

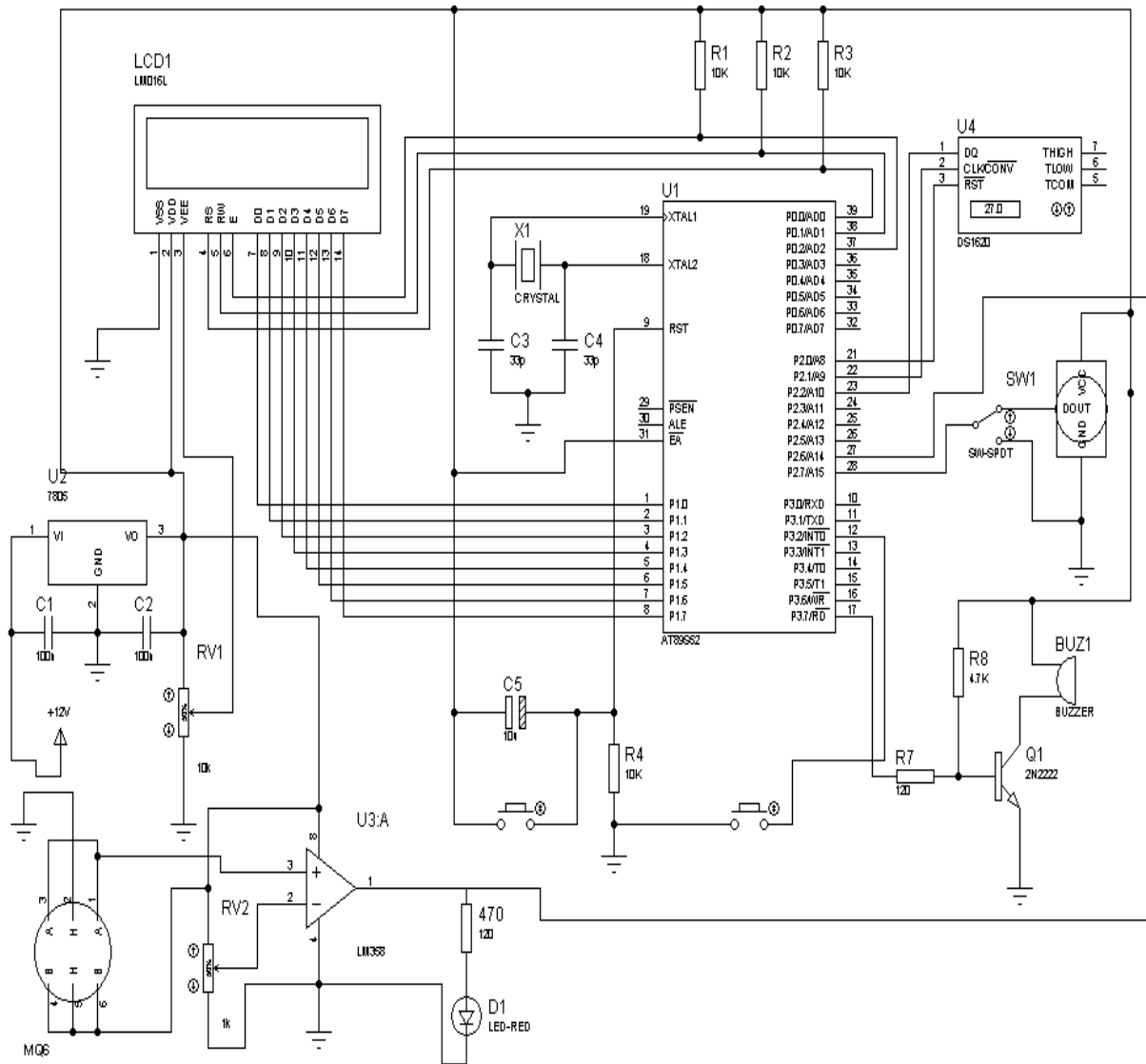

N.B1-Since serial communication cannot be simulated using proteus, so the serial communication pins are left blank in the simulated figure. The RX pin of microcontroller is connected to TX pin of SIM900 and TX pin of microcontroller is connected to the RX pin of SIM900.

N.B2- The rechargeable battery is connected in the path of main current source.

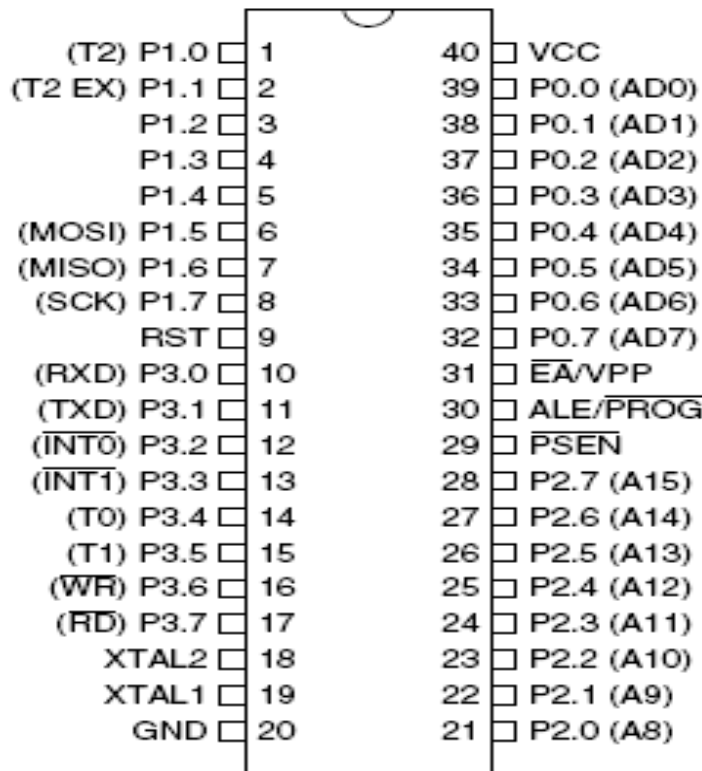
WORKING PRINCIPLE
AT89S52 MICROCONTROLLER*fig1: Pin diagram of microcontroller***Description:**

The microcontroller used for the purpose is AT89S52 developed by Atmel. The AT89S52 is a low-power, high-performance CMOS 8-bit microcontroller with 8K bytes of in-system programmable Flash memory.

Sub-subheading should be 10pt Times new roman, Italic, Justified.

There are 4 8-bit ports: P0, P1, P2 and P3.

PORT P0 (pins 32 to 39): Port 0 is an 8-bit open drain bidirectional I/O port. As an output port, each pin can sink eight TTL inputs. When 1s are written to port 0 pins, the pins can be used as high-impedance inputs. Port 0 can also be configured to be the multiplexed low-order address/data bus during accesses to external program and data memory. In this mode, P0 has internal pull-ups. Port 0 also receives the code bytes during Flash programming and outputs the code bytes during program verification. External pull-ups are required during program verification.

PORT P1 (Pins 1 to 8): The port P1 is a general purpose input/output port which can be used for a variety of interfacing tasks. The other ports P0, P2 and P3 have dual roles or additional functions associated with them based upon the context of their usage. The port 1 output buffers can sink/source four TTL inputs. When 1s are written to port 1 pins are pulled high by the internal pull-ups and can be used as inputs.

PORT P3 (Pins 10 to 17): PORT P3 acts as a normal IO port, but Port P3 has additional functions such as, serial transmit and receive pins, 2 external interrupt pins, 2 external counter inputs, read and write pins for memory access.

PORT P2 (pins 21 to 28): PORT P2 can also be used as a general purpose 8 bit port when no external memory is present, but if external memory access is required then PORT P2 will act as an address bus in conjunction with

PORT P0 to access external memory. Port 3 also serves the functions of various special features of the AT89S52, as shown in the following table:

Port Pin	Alternate Functions
P3.0	RXD (serial input port)
P3.1	TXD (serial output port)
P3.2	INTD (external interrupt 0)
P3.3	INT1 (external interrupt 1)
P34	T0 (timer 0 external input)
P35	T1(timer 1 external input)
P3.6	WR (external data memory write strobe)
P3.7	RD (external data memory read strobe)

JHD162A LCD



fig2: JHD162A LCD

A liquid crystal display (LCD) is a flat panel display, electronic visual display, or video display that uses the light modulating properties of liquid crystals (LCs). LCs do not emit light directly.

Pin Description

PIN number	Symbol	Function
1	Vss	GND
2	Vdd	+3V or +5V
3	Vo	Contrast Adjustment
4	RS	H/L Register Select signal
5	R/W	H/L Read/Write signal

6	E	H-L Enable signal
7	DB0	H/L Data Bus Line
8	DB1	H/L Data Bus Line
9	DB2	H/L Data Bus Line
10	DB3	H/L Data Bus Line
11	DB4	H/L Data Bus Line
12	DB5	H/L Data Bus Line
13	DB6	H/L Data Bus Line
14	DB7	H/L Data Bus Line
15	A/Vee	+4.2V for LED/ Negative Voltage Output
16	K	Power Supply for B/L line

LCD interfacing with 8051

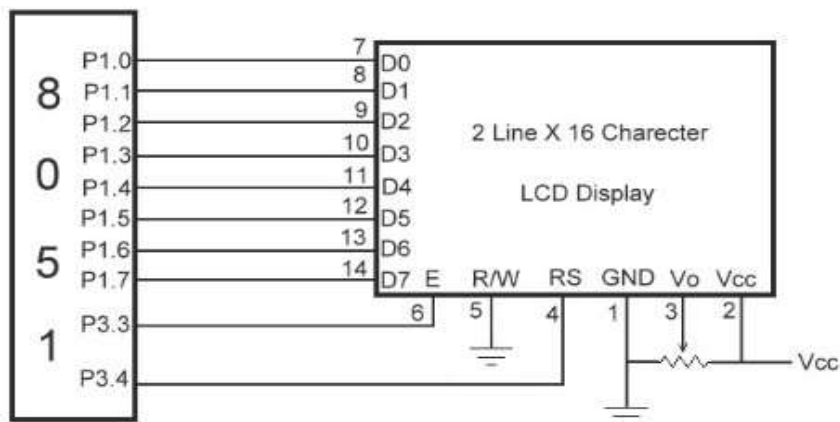

fig3: LCD interfacing with 8051

Vcc and Vss provides +5V and ground respectively. The Data pins, D0-D7 are used to send information to the LCD or read the contents of the LCD's internal registers. These pins are connected to the port 1 of microcontroller through pin p1.0-p1.7. To display number and letters, we send ASCII code for the letter A-Z, a-z, and numbers 0-9. There are instructions codes that can be sent to the LCD to clear the display and force the command to the home position. RS register is a very important register inside the LCD. If RS=0, the instruction command code register is

selected and if RS=1, the data register is selected, allowing the user to send data. The LPG gas detector will sense the amount of LPG leaked in the air and it will display the same with the help of microcontroller to the LCD. At the same time, the LCD will also display the room temperature, sensed by DSI 620 by interfacing with microcontroller. The status of the PIR sensor is displayed on the LCD continuously. If PIR senses human motion, then the status will be "PIR=ACTIVE", otherwise "PIR=CLEAR". All these data are displayed on the LCD screen by using a suitable program written in C for 8051.

DS1620 TEMPERATURE SENSOR

DESCRIPTION:

The DS1620 Digital Thermometer and Thermostat provides 9-bit temperature readings which indicate the temperature of the device. With three thermal alarm outputs, the DS1620 can also act as a thermostat. THIGH is driven high if the DS1620's temperature is greater than or equal to a user-defined temperature TH. TLOW is driven high if the DS1620's temperature is less than or equal to a user-defined temperature TL. TCOM is driven high when the temperature exceeds TH and stays high until the temperature falls below that of TL. In the project, DS1620 is used to measure the environmental temperature continuously and to produce alarm when the temperature exceeds a certain limit.

PIN ASSIGNMENT:

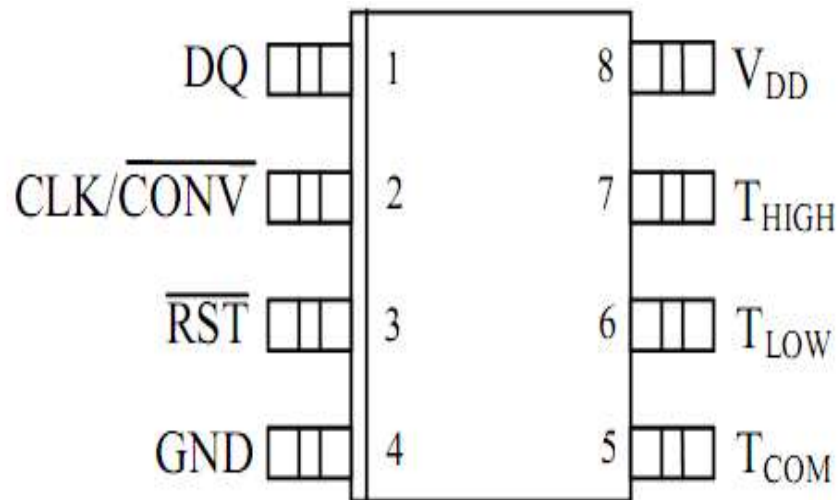

fig4: pin diagram of DS1620

PIN DESCRIPTION:

- DQ- 3-Wire Input/ Output.
- CLK/CONV - 3-Wire Clock Input and Stand-alone Convert Input.
- RST - 3-Wire Reset Input.

- GND- Ground.
- THIGH - High Temperature Trigger.
- TLOW - Low Temperature Trigger.
- TCOM - High/Low Combination Trigger.
- VDD - Power Supply Voltage (3V - 5V).

3-WIRE COMMUNICATION:

The 3-wire bus is comprised of three signals. These are the RST (reset) signal, the CLK (clock) signal, and the DQ (data) signal. All data transfers are initiated by driving the RST input high. Driving the RST input low terminates communication. A clock cycle is a sequence of a falling edge followed by a rising edge. For data inputs, the data must be valid during the rising edge of a clock cycle. Data bits are output on the falling edge of the clock and remain valid through the rising edge. When reading data from the DS1620, the DQ pin goes to a high-impedance state while the clock is high. Taking RST low will terminate any communication and cause the DQ pin to go to a high-impedance state.

MQ6 GAS SENSOR-GAS DETECTION SYSTEM



fig5-MQ6 gas sensor

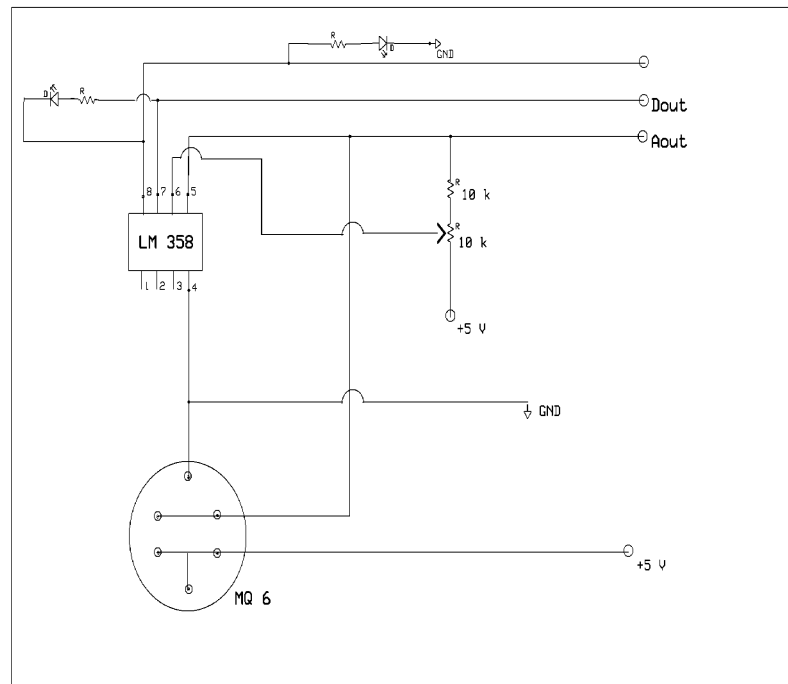

fig6-MQ6 with op-amp

Description:

This is a simple-to-use liquefied petroleum gas (LPG) sensor, suitable for sensing LPG composed of mostly propane and butane concentrations in the air. The MQ-6 can detect gas concentrations anywhere from 200 to

10000ppm. This sensor has a high sensitivity and fast response time. . Sensitive material of MQ-6 gas sensor is SnO₂, which has lower conductivity in clean air. When the target combustible gas exist, the sensor's conductivity is higher along with the gas concentration rising. Change of conductivity is converted to corresponding output signal of gas concentration. MQ-6 gas sensor has high sensitivity to Propane, Butane and LPG. It is also responsive to Natural gas. The sensor can be used to detect different combustible gas, especially Methane. It is of low cost and suitable for different applications.

+5V power is supplied to the MQ6 gas sensor. Since the output of MQ6 is low, hence the output is applied to the LM358 operational amplifier. Output of the LM358 is applied to the microcontroller. The pin 6 of the LM358 is used to provide the set point, beyond which if there is concentration of LPG in the vicinity of the sensor, it detects the leakage and sets up an alarm. A variable of 10K ohm resistor is connected to achieve the mentioned purpose.

PIR SENSOR



fig7-PIR sensor

Description:

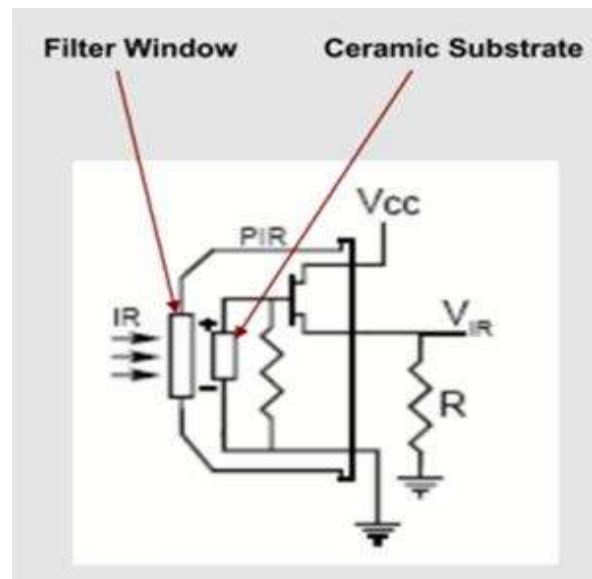

fig8-charge amplification process

The PIR Sensor Switch can detect the Infrared Rays released by human body. . It is an electronic sensor that measures infrared (IR) light radiating from objects in its field of view. At the core of a PIR sensor is a solid state sensor or set of sensors, made from pyroelectric materials which generate energy when exposed to heat. Typically, the sensors are approximately 1/4 inch square (40 mm²), and take the form of a thin film. Materials commonly used in PIR sensors include gallium nitride (GaN), caesium nitrate (CsNO₃), polyvinyl fluorides, derivatives of phenylpyrazine, and cobalt phthalocyanine.

If PIR Motion Sensor is installed in front yard or back yard of our house, it works as Security Sensor in nights. As if anybody jumps or sneaks within its detection range, the connected lights / Sirens or beeps can be activated automatically to create Panic to the Intruder.

GSM MODEM: SIM900



Fig9-SIM900

Description:

A GSM Module like SIM-300 can be used for any embedded application that requires a long range communication. The modem can be used for sending/receiving SMS, making and receiving calls. All of these functions need some AT commands to be used. SIM 300 is a Tri-band GSM/GPRS engine that works on frequencies EGSM 900 MHz, DCS 1800 MHz and PCS 1900 MHz

The physical interface to the mobile application is made through a 60 pins board-to-board connector, which provides all hardware interfaces between the module and customers boards except the RF antenna interface.

The SIM300 is designed with power saving technique, the current consumption to as low as 2.5mA in SLEEP mode.

Features:

- Communication is through RS232 i.e., serial port.
- The baud rate can be changed.
- Can be used for SMS, IVRS, and/or GPRS based projects.
- Easy to adopt the GSM facility to any project
- The GSM modem is also available with casing and also in USB interface.

Communication Options: We have few communication options depending on the application, they may be as follows.

- Simple SMS based communication:

- Turning on/off loads using simple SMS commands, so the controlling device is a standard handset. We can use any mobile phone to control the device.
- An intruder alarm/fire alarm that informs about the panic situation such as the leakage of LPG to the house owner on his/her mobile via SMS.
- Call based communication :
 - A smart intruder alarm/fire alarm that calls the police or fire station and plays a pre recorded audio message to inform about the emergency.
- Internet Based Communication (GPRS) :
 - We can control the end application using any PC/Tablet/Mobile with internet connection. Example: LED Message Displays installed to inform users or traffic conditions ahead.

In this project, GSM SIM900 is used for simple sms based communication. Whenever the sensors detect, accordingly SIM900 will inform the concerned person by sending message. The message format is put into the microcontroller through embedded c programming.

The SIM900 KIT is a fully integrated module with SIM card holder, power supply etc. This module can be easily connected with low cost MCUs like 8051. The basic communication of LPG, we can get a GSM acknowledgement on our cell phones. Moreover, the GSM acknowledgement of the status of environmental temperature and intruder detection can be conveniently achieved.

SOFTWARE COMPONENTS:

The software components used here are

- Embedded C
- KEIL μ Vision3
- Proteus software for simulation

EMBEDDED C:

The programming Language used here in this project is an Embedded C Language. This Embedded C Language is different from the generic C language in few things like

- a) Data types
- b) Access over the architecture addresses.

The Embedded C Programming Language forms the user friendly language with access over Port addresses, SFR Register addresses etc.

KEIL μ Vision3:

Keil Software development tools are used to create products for practically every industry: consumer electronics, industrial control, networking, office automation, automotive, space exploration. With Micro Vision, we can easily create embedded applications in a mixture of C and assembly. Real-time applications benefit from our highly optimized C libraries and real-time kernels.

MicroVision3 provides a centralized front-end interface for the compiler, assembler, linker, debugger, and other development tools. The Project Window in MicroVision3 displays the current target, groups, and source files that comprise the project.

PROTEUS SOFTWARE:

Proteus is the best simulation software for various designs with microcontroller. It is mainly popular because of availability of almost all microcontrollers in it. So it is a handy tool to test programs and embedded designs for electronics hobbyist. One can simulate his programming of microcontroller in Proteus Simulation Software. After simulating the circuit in Proteus Software, one can directly make PCB design with it so it could be all in one package for students and hobbyists.

RESULTS AND DISCUSSION

With this circuit diagram, all the sensors are working. In future, the panic switch can be made wireless. With the addition of Web cam and GPRS functionality, online monitoring of the parameters of home/office/industry can also be possible.

CONCLUSION

GSM network will help in monitoring the safety parameters from remote area. The microcontroller used here helps in interfacing many input/output devices at a time. These extensive capabilities of this system make the product very interesting. The end product will have a simple design making it easy for users to interact with. The project is a small implementation of concepts in monitoring the parameters for the safety of the house/industries/offices. The practical applications of this project are immense and can have vast level of implementation. The project work infect gives a lot of confidence to fight out in this challenging world.

ACKNOWLEDGEMENTS

With immense pleasure, I take this opportunity to express my sense of gratitude and appreciation to my respected project guide Dr. Nilanjana Barua mam (Associate Professor) of the department of Electrical engineering, jorhat Engineering College, for her precious guidance, encouragement, constructive criticism and valuable suggestions during the course of project work and in preparation of the manuscript. I thank all the faculty members of the college who helped me directly or indirectly in preparing this project work.

REFERENCES

- [1] Electronics for you.
- [2] Embedded Programming in Assembly and C by Mazidi and Mazidi.
- [3] Keil documentation (help).
- [4] www.atmel.com.
- [5] www.deas.in.
- [6] www.engineersgarage.com.
- [7] www.projectsof8051.com.
- [8] www.electronicshub.org.

AUTHOR BIBLIOGRAPHY

	<p>Kapil Sekhar Borah, M.E student, Electrical Department, Instrumentation & Control specialization, Jorhat Engineering College Email: sekhar.kapil13@gmail.com</p>
---	--